

# MCAS PRACTICE

## Solve for x

**1** The steps a student took to solve an equation are shown below.

$$\frac{3}{4}(-8x + 20) = -8(-x - 3)$$

**Step 1:**  $-6x + 15 = 8x + 24$

**Step 2:**  $15 = 2x + 24$

**Step 3:**  $-9 = 2x$

**Step 4:**  $x = -\frac{9}{2}$

What error did the student make and what is the correct value of  $x$ ?

**2** An equation is shown below.

$$3(x - 2) + 7x = \frac{1}{2}(6x - 2)$$

How many solutions, if any, does the equation have?

**3** What is the solution, if any, to the equation  $3(x - 2) + 4 = 3x + 6$ ?

- A**  $x = 0$
- B**  $x = 8$
- C** There is no solution.
- D** There are an infinite number of solutions.

**4** An equation is shown below.

$$5(2x + 1) - 3x = 7x + 5$$

How many solutions, if any, does the equation have?

## Linear

5

Which equation describes a linear function?

- A**  $V = s^3$       **C**  $y = (2)^x$   
**B**  $y = \left(\frac{1}{6}\right)x$       **D**  $A = \pi r^2$

6

The points  $(4, 1)$  and  $(x, -6)$  lie on the same line. If the slope of the line is 1, what is the value of  $x$ ?

- A**  $x = -3$   
**B**  $x = 3$   
**C**  $x = 9$   
**D**  $x = 11$

7

Functions W and Z are both linear functions of  $x$ .

**Function W**  
 $y = -\frac{1}{16}x + 30$

**Function Z**

$x$	0	1	2	3
$y$	15.8	15.76	15.72	15.68

Which statement comparing the functions is true?

- A** The slope of Function W is equal to the slope of Function Z.  
**B** The slope of Function W is less than the slope of Function Z.  
**C** The  $y$ -intercept of Function W is equal to the  $y$ -intercept of Function Z.  
**D** The  $y$ -intercept of Function W is less than the  $y$ -intercept of Function Z.

8

Line  $n$  passes through the points  $(-3, -7.5)$  and  $(2, -5)$ . Tahlia determined that the equation of line  $n$  is  $y = 0.5x$ . Explain the error Tahlia made while determining her equation. Be sure to include the correct equation in your explanation.

9

Kevin and Christy both saved money for their class trip. Kevin saved the same amount each week. The total amount that Kevin saved at the end of every two weeks is shown in the table below.

**KEVIN'S SAVINGS**

Time (weeks)	Total Amount Saved
2	\$46
4	\$92
6	\$138

Christy's savings can be modeled by the equation  $y = 26x$ , where  $y$  is the total amount of money saved in  $x$  weeks. Which statement correctly compares the rates at which Kevin and Christy saved money?

- A Christy saved \$3 per week more than Kevin.
- B Kevin saved \$10 per week more than Christy.
- C Christy saved \$18 per week more than Kevin.
- D Kevin saved \$20 per week more than Christy.

10

Charles needs to fill a large fish tank with water using a hose. He has two hoses from which to choose. Water flows through each hose at a constant rate. The graph below shows the amount of water, in gallons, that flows through Hose A based on the number of minutes used.

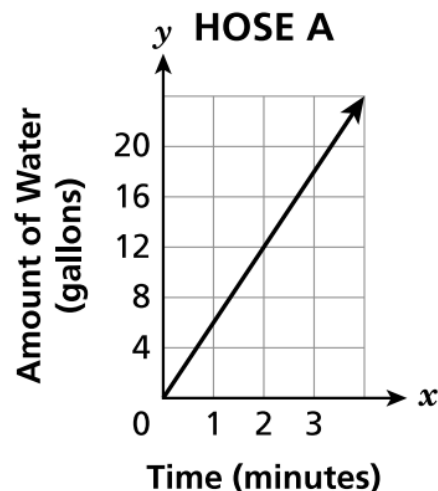

A total of 110 gallons of water can flow through Hose B in 10 minutes. Which hose has a faster water flow rate, in gallons per minute, and what is that rate?

11

The scatter plot below can be used to find the approximate rate at which water flows through a garden hose. The line of best fit for the scatter plot can be described by the equation  $y = \frac{4}{5}x$ .

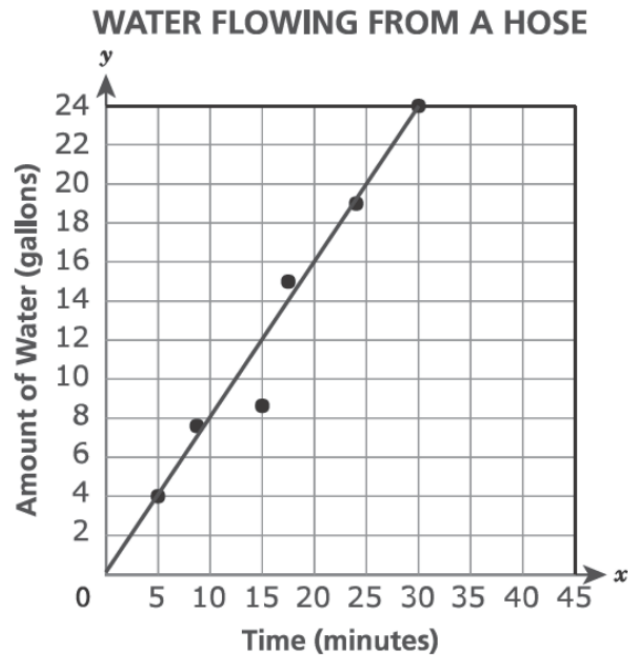

If the rate, in gallons per minute, continues, approximately how many gallons of water will flow from the hose in 45 minutes?

- A 24      C 39  
B 36      D 56

12

Which function of  $x$  has the **least** value for the  $y$ -intercept?

- A  $y = -4x + 15$       C  $y = 2x - 3$

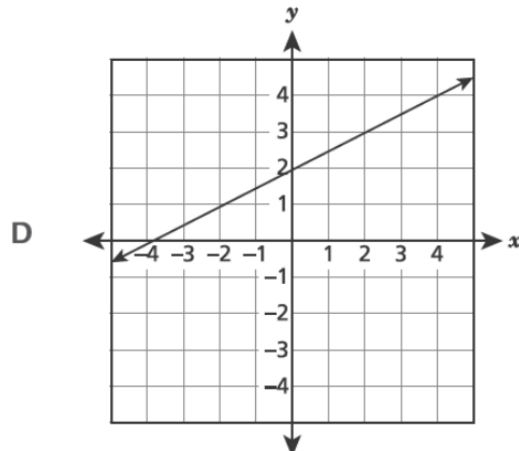
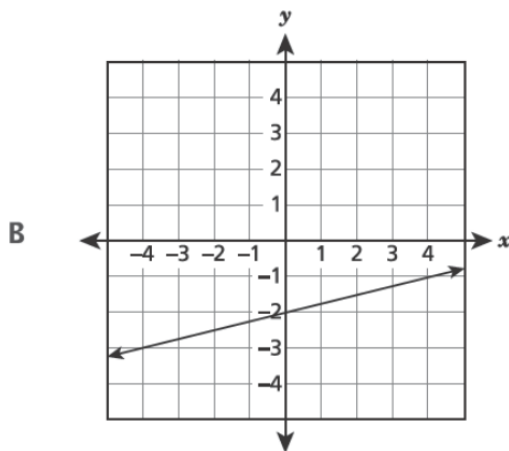

13

A set of data is represented on the scatter plot below.

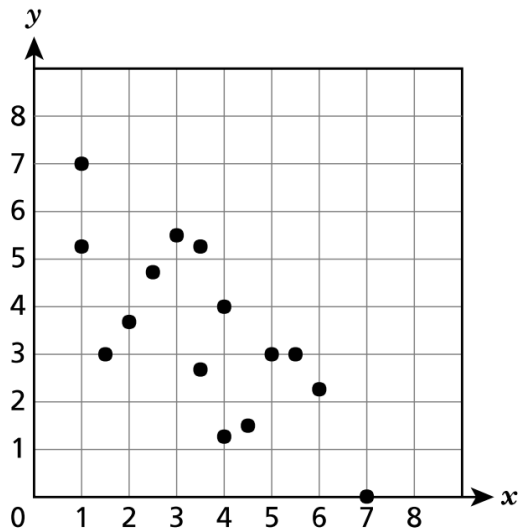

Which equation **best** models the set of data?

A  $y = -\frac{3}{4}x + 6$

C  $y = -6x + \frac{3}{4}$

B  $y = \frac{3}{4}x - 6$

D  $y = 6x - \frac{3}{4}$

14

The scatter plot below shows the average points scored per game by players of different ages in an adult basketball league.

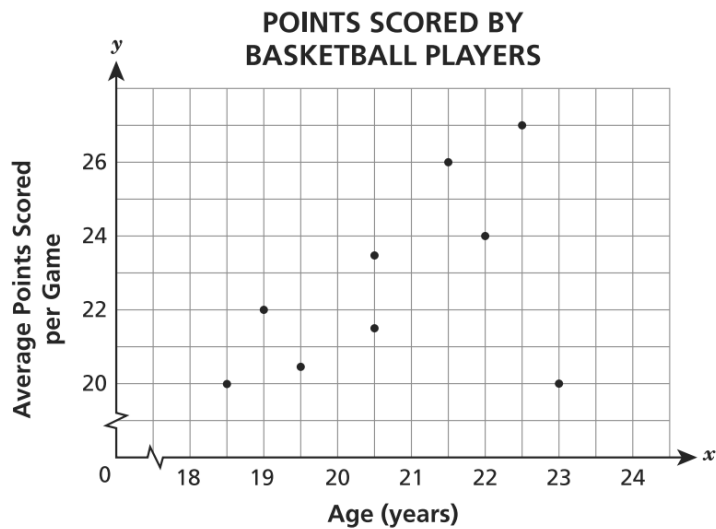

Which statement **best** describes the association between a player's age, in years, and the average points scored per game?

- A There is no association.
- B There is a nonlinear association.
- C There is a positive linear association and one outlier.
- D There is a negative linear association and one outlier.

## Systems of Equations

15

A system of equations is shown below.

$$5x + 2y = -15$$

$$2x - 2y = -6$$

What is the solution to the system of equations?

**A**  $(-3, 0)$

**B**  $(0, -3)$

**C**  $(-3, 6)$

**D**  $(6, -3)$

16

At a local basketball game, all tickets are the same price and all souvenirs are the same price. Mr. Smith bought 2 tickets to this basketball game and 1 souvenir for a total of \$17.25. Ms. Lockhart bought 5 tickets to the same game and 2 souvenirs for a total of \$42.00. How much was a ticket to this game?

**A** \$2.25

**B** \$7.50

**C** \$8.50

**D** \$9.75

17

A school district transported a total of 409 students and teachers to a zoo in buses and vans.

- Each bus transported a total of 55 students and teachers.
- Each van transported a total of 12 students and teachers.
- There were 5 more buses than vans.

What is the total number of students and teachers who rode to the zoo in buses?

What is the total number of students and teachers who rode to the zoo in vans?

# Functions

18

In each table,  $x$  represents the input value and  $y$  represents the output value. Which table does **not** represent a function of  $x$ ?

A

$x$	$y$
0	0
1	1
2	2
3	3

C

$x$	$y$
0	3
1	3
2	3
3	3

B

$x$	$y$
3	0
2	1
1	2
0	3

D

$x$	$y$
3	0
3	1
3	2
3	3

19

The table and graph shown below each represent a function of  $x$ .

FUNCTION A

$x$	$y$
1	5
2	7
3	9
5	13
6	15

FUNCTION B

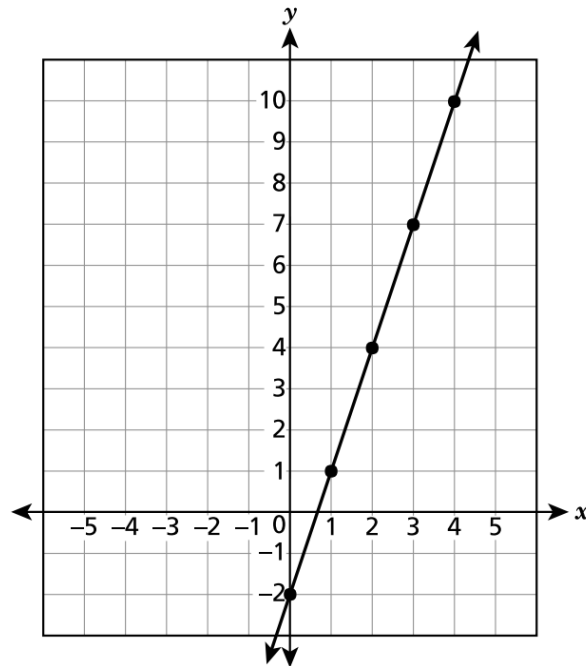

Which function, A or B, has a greater rate of change? Be sure to include the values for the rates of change in your answer.

Which graph represents a function that is increasing?

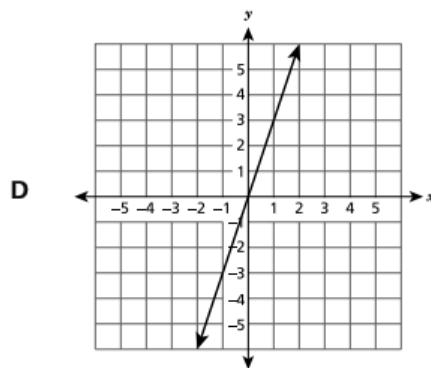
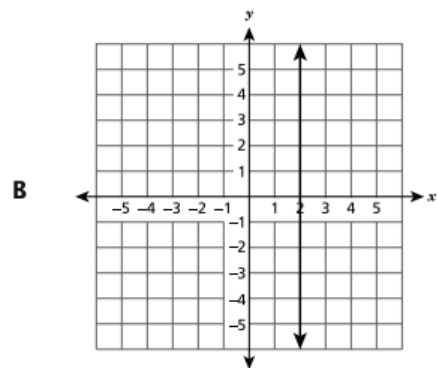
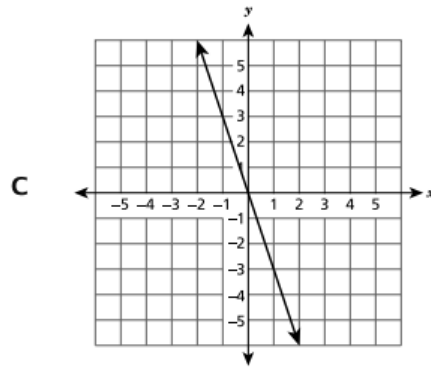
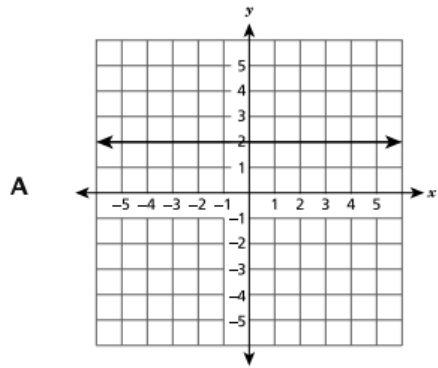

Which set of ordered pairs  $(x, y)$  could represent a linear function of  $x$ ?

- A**  $\{(-2, 8), (0, 4), (2, 3), (4, 2)\}$
- B**  $\{(1, 2), (1, 3), (1, 4), (1, 5)\}$
- C**  $\{(-2, 7), (0, 12), (2, 17), (4, 22)\}$
- D**  $\{(3, 5), (4, 7), (3, 9), (5, 11)\}$



## Exponents and Scientific Notation

22 Which expression is equivalent to  $(15^3)(15^{-7})$ ?

A  $15^{-21}$

B  $-15^4$

C  $\frac{1}{15^4}$

D  $\frac{1}{15^{-4}}$

23 Which equation has **both** 4 and -4 as possible values of  $y$ ?

Ⓐ  $y^2 = 8$

Ⓑ  $y^3 = 8$

Ⓒ  $y^2 = 16$

Ⓓ  $y^3 = 64$

24 Which expression is equivalent to  $4^{-5} \times 4^8$ ?

A  $\frac{4^{-2}}{4^{-1}}$

B  $(4^3)^{-1}$

C  $\frac{4^2}{4^{-1}}$

D  $(4^{-1})^3$

25 Which expressions are equivalent to  $\frac{3^{-8}}{3^{-4}}$ ?

Select **all** that apply.

Ⓐ  $3^{-12}$

Ⓓ  $\frac{1}{3^2}$

Ⓑ  $3^{-4}$

Ⓔ  $\frac{1}{3^4}$

Ⓒ  $3^2$

Ⓕ  $\frac{1}{3^{12}}$

26 Consider this expression.

$$\frac{3^{-2} \cdot 3^3}{3^{-1}}$$

What is the value of the expression?

27 What value of  $x$  makes the equation below true?

$$9^5 \cdot 9^7 = 9^x$$

28 City X has a population of  $3 \times 10^5$  and City Y has a population of  $6 \times 10^6$ . Which statement correctly describes the relationship between the populations of City X and City Y?

- A The population of City Y is 2 times the population of City X.
- B The population of City Y is 20 times the population of City X.
- C The population of City X is 300,000 less than the population of City Y.
- D The population of City X is 3,000,000 less than the population of City Y.

29 The mass of Earth is approximately  $5.97 \times 10^{24}$  kilograms. The mass of Venus is approximately 4,870,000,000,000,000,000,000,000 kilograms. What is the difference between the approximate masses, in kilograms, of Earth and Venus? Express your answer in scientific notation.

30 Two cells are viewed and measured under a microscope. The approximate diameter of each cell is listed below.

- cell P:  $5.0 \times 10^{-4}$  meters
- cell Q:  $3.0 \times 10^{-5}$  meters

What is the approximate difference, in meters, between the diameter of cell P and the diameter of cell Q?

- A  $2.0 \times 10^{-5}$
- B  $2.0 \times 10^{-4}$
- C  $4.7 \times 10^{-5}$
- D  $4.7 \times 10^{-4}$

## Angles

31 Which set of angle measures could be the interior angles of a triangle?

- A  $90^\circ, 90^\circ, 90^\circ$
- B  $80^\circ, 80^\circ, 200^\circ$
- C  $40^\circ, 50^\circ, 60^\circ$
- D  $15^\circ, 30^\circ, 135^\circ$

32 Lines  $l$  and  $m$  are parallel and intersect transversal  $p$ , as shown in the diagram below.

What is the value of  $n$ ?

- A 6
- B 10
- C 20
- D 24

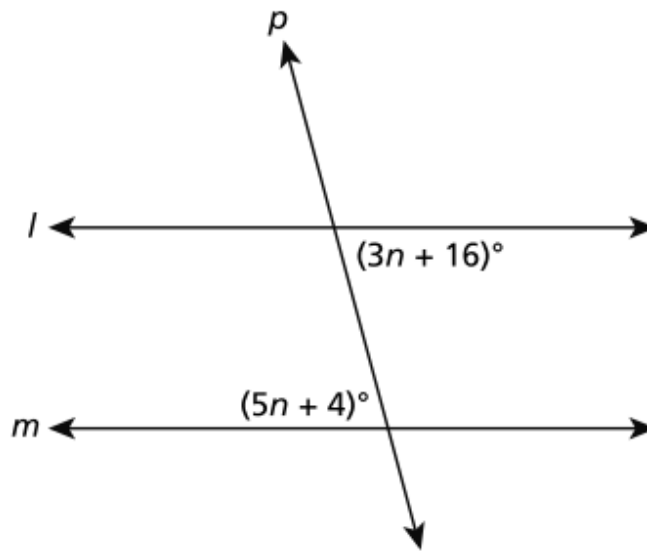

33 Two intersecting lines,  $l$  and  $t$ , are shown in the diagram below.

If  $y = 115$ , what is the value of  $x$ ?

- A 40
- B 50
- C 65
- D 115

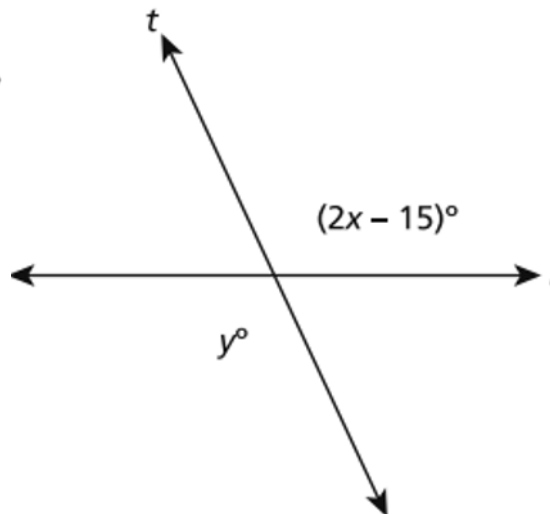

34

Mya claims  $(m\angle 3 + m\angle 4) = m\angle 1$ , as shown in the triangle below.

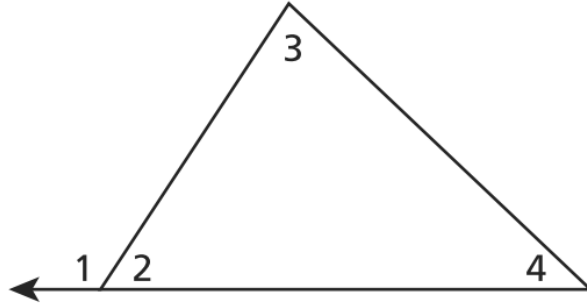

Which equations explain why Mya's claim must be true?

- A  $(m\angle 1 + m\angle 2) = 90^\circ$  and  $(m\angle 3 + m\angle 4) = 90^\circ$
- B  $(m\angle 1 + m\angle 2) = 180^\circ$  and  $(m\angle 3 + m\angle 4) = 180^\circ$
- C  $(m\angle 1 + m\angle 2) = 90^\circ$  and  $(m\angle 3 + m\angle 4 + m\angle 2) = 90^\circ$
- D  $(m\angle 1 + m\angle 2) = 180^\circ$  and  $(m\angle 3 + m\angle 4 + m\angle 2) = 180^\circ$

35

In the figure shown below,  $\overleftrightarrow{AC}$  is parallel to  $\overleftrightarrow{DE}$  with transversal  $\overleftrightarrow{BF}$ .

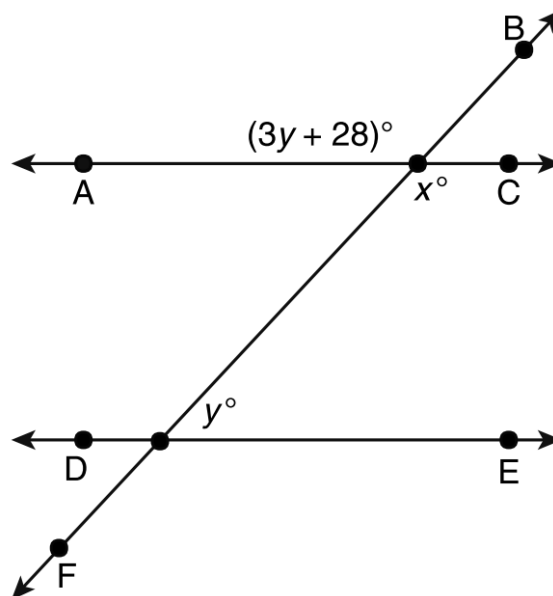

Determine the values of  $x$  and  $y$ .

## Transformations

36

On a coordinate plane, vertex A for triangle ABC is located at (6, 4). Triangle ABC is dilated by a scale factor of 0.5 with the center of dilation at the origin. The resulting image is triangle  $A'B'C'$ . What are the coordinates of vertex  $A'$ ?

- A (3, 2)
- B (12, 8)
- C (5.5, 3.5)
- D (6.5, 4.5)

37

Triangle BCD is rotated  $180^\circ$  clockwise and then dilated by a factor of 4 centered at the origin. The resulting image is triangle  $B'C'D'$ . Which statement about the two triangles is true?

- A The area of  $\triangle BCD$  is 4 times the area of  $\triangle B'C'D'$ .
- B The perimeter of  $\triangle BCD$  is 4 times the perimeter of  $\triangle B'C'D'$ .
- C The corresponding sides of  $\triangle BCD$  and  $\triangle B'C'D'$  are congruent.
- D The corresponding angles of  $\triangle BCD$  and  $\triangle B'C'D'$  are congruent.

38

On the coordinate plane below, rectangle ABCD is rotated  $90^\circ$  clockwise about the origin to form rectangle WXYZ.

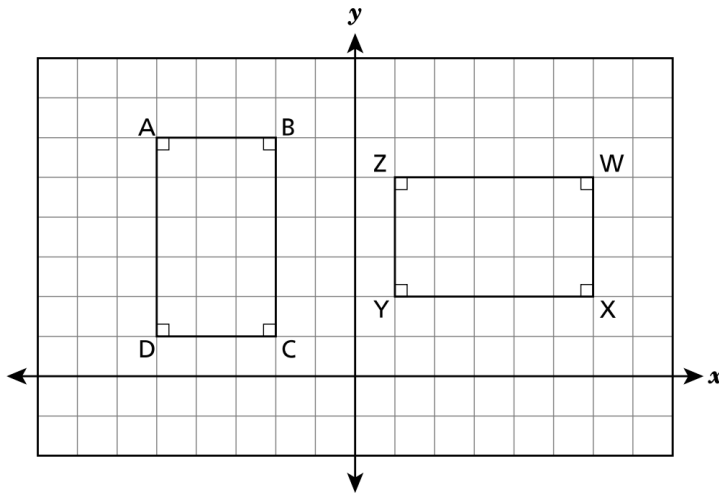

Which statement about the relationship between rectangle ABCD and rectangle WXYZ is true?

- A  $\overline{DA} \cong \overline{YZ}$
- B  $\overline{DC} \cong \overline{XY}$
- C  $\overline{BC} \cong \overline{YZ}$
- D  $\overline{AB} \cong \overline{WX}$

39

Trapezoid RSTU and trapezoid NMLK shown on the coordinate plane are congruent.

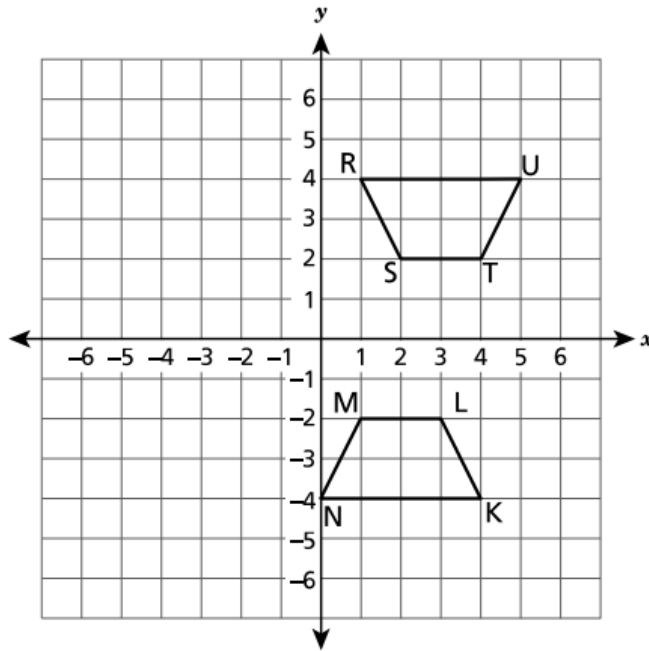

Which sequence of transformations will map trapezoid RSTU onto trapezoid NMLK?

- A a reflection over the  $y$ -axis, then a translation 1 unit to the right
- B a reflection over the  $x$ -axis, then a translation 1 unit to the left
- C a reflection over the  $y$ -axis, then a translation 1 unit down
- D a reflection over the  $x$ -axis, then a translation 1 unit up

40

Triangle P undergoes a sequence of transformations resulting in triangle Q. Which sequence of transformations could be used to show that triangle Q is similar but not congruent to triangle P?

- A a reflection followed by a translation
- B a rotation followed by a reflection
- C a reflection followed by a rotation
- D a translation followed by a dilation

41

Square ABCD is located on a coordinate plane. The coordinates for three of the vertices are listed below.

- A (2, 7)
- C (8, 1)
- D (2, 1)

Square ABCD is dilated by a scale factor of 2 with the center of dilation at the origin, to form square  $A'B'C'D'$ . What are the coordinates of vertex  $B'$ ?

## Measurement

42

The octagon shown below has eight congruent sides. The given measures of the octagon are rounded to the nearest tenth of a centimeter.

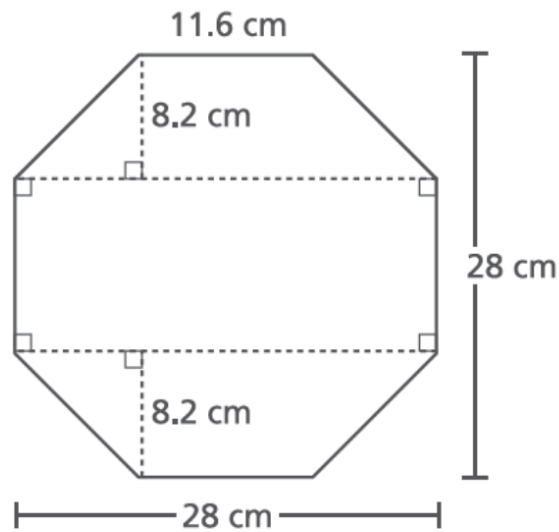

What is the area, to the nearest square centimeter, of the octagon?

- A 392
- B 487
- C 650
- D 720

43

There are two boxes of cereal in the shape of rectangular prisms on a shelf. The dimensions of each box of cereal are listed below.

- Box A has a height of 25 centimeters, a length of 20 centimeters, and a width of 9 centimeters.
- Box B has a height of 25 centimeters, a length of 19 centimeters, and a width of 6 centimeters.

What is the difference in volume, in cubic centimeters, between the two boxes of cereal?

- A 1,650
- B 3,900
- C 4,500
- D 7,350

**44**

The object below is made of solid plastic. It is a cylinder with an indentation at the top in the shape of a cone.

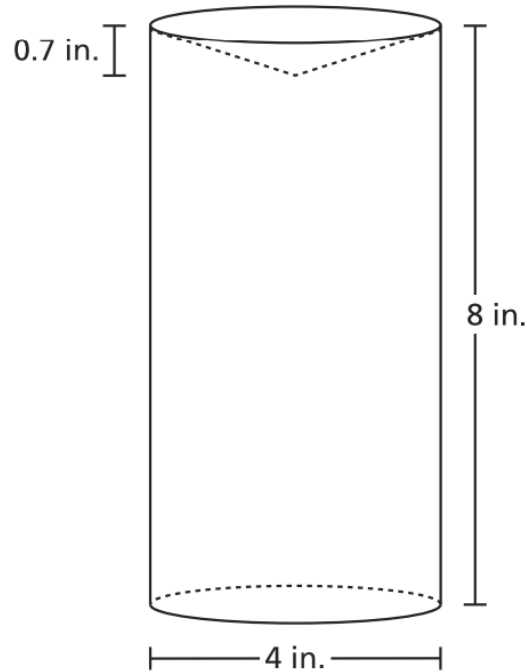

What is the volume, to the nearest tenth of a cubic inch, of the plastic object?

- A 103.5
- B 100.4
- C 97.6
- D 91.7

**45**

At the beach, a child uses a container in the shape of a cylinder to build a sand castle. The child completely fills the container with sand.

- The container has a height of 10 inches and a diameter of 12 inches.
- There are 231 cubic inches in one gallon of sand.

What is the approximate volume of sand, in gallons, in the container? Round your answer to the nearest gallon.



## Additional Topics

46

A newspaper conducted a survey to find out how many high school students play video games. The two-way table below displays the data from the survey.

**VIDEO GAME SURVEY**

	Boys	Girls	Total
Do Play Video Games	1,593	1,361	2,954
Do Not Play Video Games	858	1,635	2,493
Total	2,451	2,996	5,447

Based on these data in the table, which statement is true?

- A There were 2,451 boys surveyed, and about 29% of them play video games.
- B There were 2,996 girls surveyed, and about 45% of them play video games.
- C There were 5,447 students surveyed, and about 54% of them do not play video games.
- D There were 2,493 students surveyed, and about 34% of them are girls who do not play video games.

47

A principal surveyed 75 seventh-grade and eighth-grade students. She asked them if they prefer to obtain news from the Internet or to obtain news from television. She created a table to display the data, as shown.

		News Preference	
		Internet	Television
Students	Seventh Grade	16	34
	Eighth Grade	10	15

Based on the table, select the **three** correct statements.

- A 49 eighth-grade students participated in the survey.
- B 50 seventh-grade students participated in the survey.
- C 26 out of 49 students prefer to obtain news from the Internet.
- D 3 out of 5 eighth-grade students prefer to obtain news from television.
- E 8 out of 25 seventh-grade students prefer to obtain news from the Internet.

48

Between which pair of numbers on a number line does  $\sqrt{6}$  lie?

- (A) 2.3 and 2.5
- (B) 2.5 and 2.7
- (C) 2.7 and 2.9
- (D) 2.9 and 3.1

49

The length of one side of a right triangle is shown in this diagram.

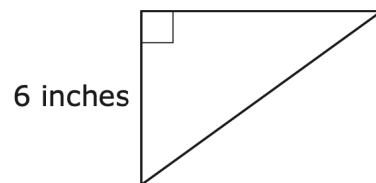

What could be the lengths of the two remaining sides of the triangle?

- (A) 2 inches and 8 inches
- (B) 8 inches and 10 inches
- (C) 8 inches and 14 inches
- (D) 10 inches and 14 inches

50

Right triangle  $JAZ$  has a base of 5 centimeters and a height of 8 centimeters, as shown.

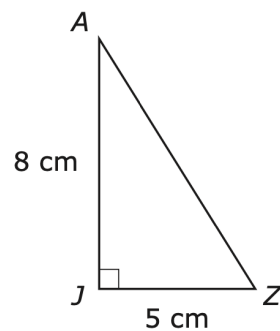

Which of the following pairs of dimensions could represent a triangle that is similar to triangle  $JAZ$ ?

- (A) base = 9 cm  
height = 12 cm
- (B) base = 8 cm  
height = 11 cm
- (C) base = 10 cm  
height = 8 cm
- (D) base = 15 cm  
height = 24 cm